

5

4

3

2

1

受控 CONTROLLED DOCUMENT

编号 P/N	25-7350-CUST	版本 Rev	01	日期 Rel'd Date	Apr29,09
-----------	--------------	-----------	----	------------------	----------

DRAWING NO.

25-7350-CUST

REVISIONS

01	OFFICIAL RELEASE				Thomas Chow
	03-05-09	Y U	Y U	T H	

Description: SO-239 UHF Square Flange Mount

Part No: 25-7350

Application: PCB Mount

Crimp Tool: N/A

Impedance: N/A

Frequency Range: 0-500 MHz

Material: Body Zinc Nickel plated

Contact Bronze Nickel plated

Insulator Delrin

RoHS Compliance: Yes

Technical Detail: Refer to Emerson Document P/N 25-0001

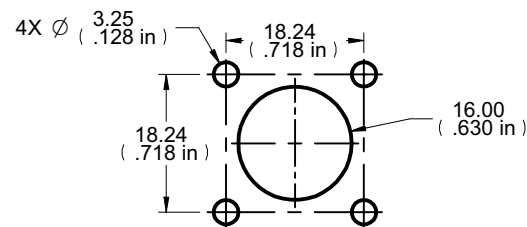

MOUNTING HOLE LAYOUT

CUSTOMER COPY

D

C

B

A

D

C

B

A

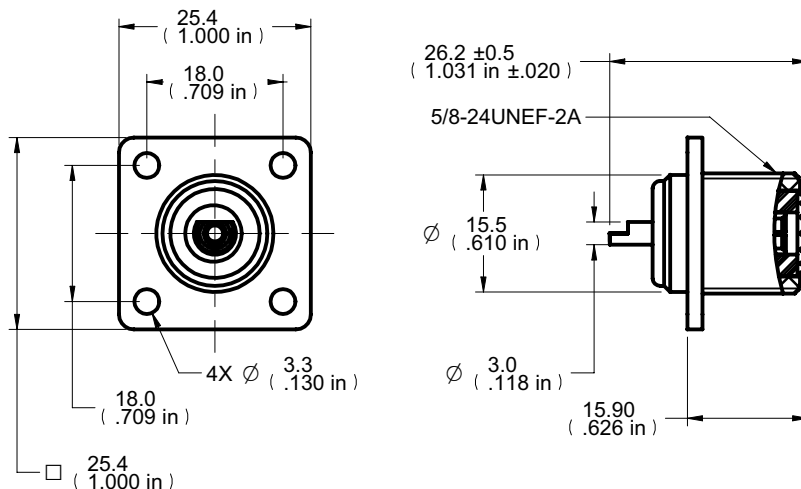

DIM OUTLINE

TOLERANCE UNLESS OTHERWISE SPECIFIED		DRAWN BY		DATE	
		BETTY.YU		03-05-09	
DECIMALS	mm	CHECKED BY		DATE	
X	± 0.5	BETTY.YU		03-05-09	
X.X	± 0.3	APPROVED BY		DATE	
X.XX	± 0.1	THOMAS		03-05-09	
ANGLES	± 0.5°	U/M	mm		

THIS DRAWING WAS PRODUCED BY COMPUTER,
DO NOT SCALE DRAWING OR UPDATE MANUALLY.SHEET
1 OF 1DRAWING NO.
25-7350-CUSTSIZE
A

5

4

3

2

1